



INSTALL CONFIDENCE



YORK® YCME / YHME & YCSE / YCRE
Modular Screw Chillers and Heat Pumps

Main Features

Twin screw compressor

Latest development of YORK's world renowned screw compressor technology. Optimised for R134a refrigerant, featuring continuous capacity control and a unique cyclonic oil chamber.

A new rotor, a lighter casing and easy access to the E-Box enhance efficiency and handling. Whilst a new bearing system allows the overhaul period to be increased to 40,000 hours.

Plate heat exchangers

The new modular screw chillers and heat pumps are equipped with true Dual-type brazed plate exchangers, manufactured from stainless steel AISI316. These plate heat exchangers have two refrigerant inlets in order to improve the distribution of gas-liquid mixtures in the interior of the evaporator. The higher efficiency and compact nature of the refrigeration system allows for accurate control of the evaporation temperature.

Moreover, the pressure loss on the water inlet side has been significantly reduced, less than 24 kPa at nominal conditions, facilitating lower input power of the circulating pumps.

Continuous capacity control

YORK's Continuous Capacity Control system uses advanced electronic controls to position the infinitely variable slide valve within each compressor. Capacity control per module is performed from 100% to 25% load linearly.

Due to the modular ability of the YCME/YHME and YCSE/YCRE series the final Chiller turndown is 100% to 3% (dependent on quantity of modules).

Modulation allows exact load control and accurate chilled water temperature without the need for expensive inverters offering significant saving compared with step control systems.

Pump kit

- Factory installed pump module
- Two versions, single or dual pump
- Two different pump sizes, standard or high head
- Incl. Filter, safety valve, venting and pump shut-off valves
- Unit dimensions remain unchanged

DC motor and fan (for YCME/YHME)

Each module is equipped with 4 DC inverter-controlled fan motors. This ensures low power consumption especially in partial load. The use of DC fan motors significantly improves the efficiency compared to conventional AC motors. The continuous speed control of all motors ensures precise regulation of airflow.

The new 4-bladed fan (710 mm) is optimized for use in the new YCME/YHME Series chillers and heat pumps:

- Low sound emissions
- Increased air throughput
- Reduced energy consumption

U-shaped heat exchanger (for YCME/YHME)

The YCME/YHME series takes advantage of the latest technology for heat exchangers. The "U" shaped style provides a 20% increase in surface area compared with the previous series. 7 mm piping ensure a high heat transfer ratio, whilst an additional subcooling circuit increases the seasonal efficiency even at low load conditions.

Electronic expansion valve

To provide greater efficiency and accuracy, all units are equipped as standard with two electronic expansion valves to ensure equal refrigerant distribution to both inlets of the plate heat exchangers. New model with higher torque and increased pulses range (656 to 5960) for improved endurance and precision.

LCD touch panel

Each YORK Model YCME/YHME and YCSE/YCRE series is equipped with its own user-friendly touch screen panel, which shows the data of the device and settings of various parameters to optimize the performance of the device allows.

- 3.5 "TFT display
- 320 × 240 pixels (QVGA)
- 65,536 colors
- Available in multiple languages
- Status indicator of the unit: pump, fan, alarm, error messages
- Operating parameters: temperature, pressure, etc.
- Display of the last 10 alarms. The software saves detailed operating parameters of the last 3 alarms (at the moment the alarm / 10 seconds before the alarm / 20 seconds before the alarm).

Modular concept

Provide Flexibility

Up to 8 modules in one water system brings important benefits:

- **Ability to configure modular chillers to fit the space.** Projects change and develop over time. In order to keep up you must be able to rely on your selected products. YORK with its modular design is an ideal solution for quick compact and space adaptable installations
- **Ability to add more modular chillers in the future.** Modular chillers allow investment to be spread to match project phases. Buildings being constructed or occupied in phases do not need the full cooling/heating capacity at the start.
- **Quick and easy module combinations.** Connecting the water piping and cables and bringing power to the modular(s) makes installation quick and easy. Up to 3 modules factory built can be ordered to simplify even more the installation on site.

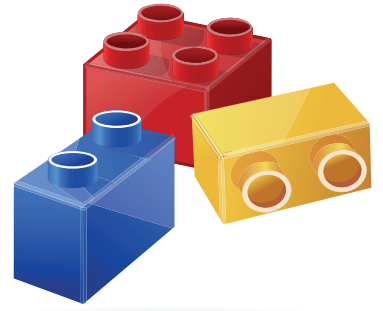

Achieve Reliability

- **Full redundancy – Safety first.** Each module has its own compressor, regulators and refrigerant circuit. Should a module fail, the remaining modules maintain operational continuity, whilst YORK's unique Dynamic Back-up Control automatically starts any standby modules. Smart defrost, automatic restart after power failure, anti-freeze pump function, automatic fan on/off cycling for snow protection, remote alarms all enhance the security of supply.

Fully configurable units

Increase the versatility

Up to 60 different options and accessories make our chiller as unique as the project needs. Some of the most interesting are the following ones:

- Three levels of sound attenuation options
- Heavy corrosion protection for the Air Heat Exchanger or for the whole module
- Service Valves (Discharge/Suction Valves, Dual pressure relief valve...)
- Modbus and BACnet BMS Gateways
- Power meters
- Pump kits available in different versions (single or dual pumps, standard or high static pressure)
- Factory package combination for two or three modules



Widest operating range at highest efficiency

Wide operating range

YCME/YHME Cooling operating range

Chilled water outlet temperature: -10°C to $+30^{\circ}\text{C}$
Ambient temperature: -15°C to $+46^{\circ}\text{C}$

YHME Heating operating range

Hot water outlet temperature: $+35^{\circ}\text{C}$ to $+55^{\circ}\text{C}$
Ambient temperature: -10°C (WB) to $+15.5^{\circ}\text{C}$ (WB)

YCSE Cooling operating range

Chilled water outlet temperature: -10°C to $+25^{\circ}\text{C}$
Heated water outlet temperature: $+22^{\circ}\text{C}$ to $+60^{\circ}\text{C}$

YCSE Heating operating range

Heated water outlet temperature: $+35^{\circ}\text{C}$ to $+55^{\circ}\text{C}$
Chilled water outlet temperature: $+5^{\circ}\text{C}$ to $+25^{\circ}\text{C}$

YCRE Cooling operating range

Chilled water outlet temperature: -10°C to $+25^{\circ}\text{C}$
Condensing temperature: $+30^{\circ}\text{C}$ to $+60^{\circ}\text{C}$

Two operating modes: High Efficiency or Accurate Water Outlet Temperature

Two operating modes selectable at commissioning allow the installation's performance to focus on either high efficiency or high accuracy outlet water temperature.

1. Accurate Water Outlet Temperature

- a. All compressors running at the same load/time
- b. 1 unique pump for all the modules constant flow

2. High Efficiency

- a. Module/Compressors start/stop "Smart Control"
- b. 1 pump for every module or stop valves & inverter pump for variable flow

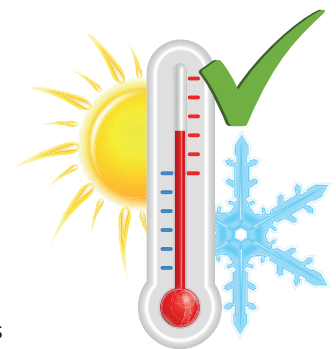



Common components and accessories

Intelligent controls

- LCD Touch Panel
- Power Meter
- ModBus Gateway
- BACnet Gateway

Continuous operational safety

- Continuous Capacity Control
- Screw Compressor
- Dual Pressure Relief Valve

High Efficiency

- Electronic Expansion Valves
- Plate Heat Exchanger

BACnet Gateway 



Power Meter 

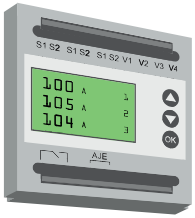

LCD Touch Panel

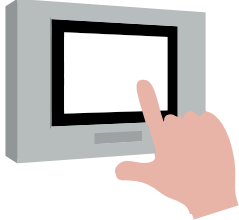

ModBus Gateway 

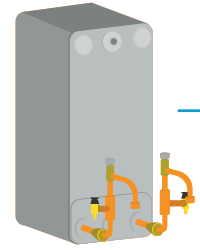
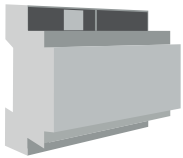

Electronic Expansion Valves



Plate Heat Exchanger

Dual Pressure Relief Valve 

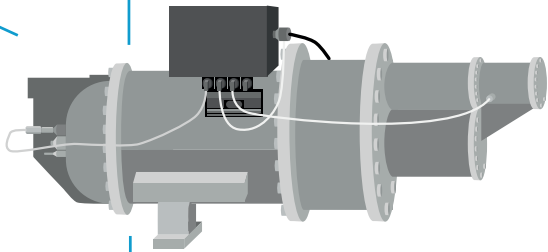

Screw Compressor

Continuous Capacity Control 

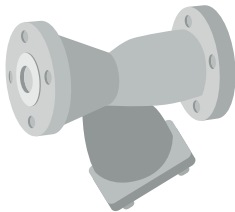

Water Filter 

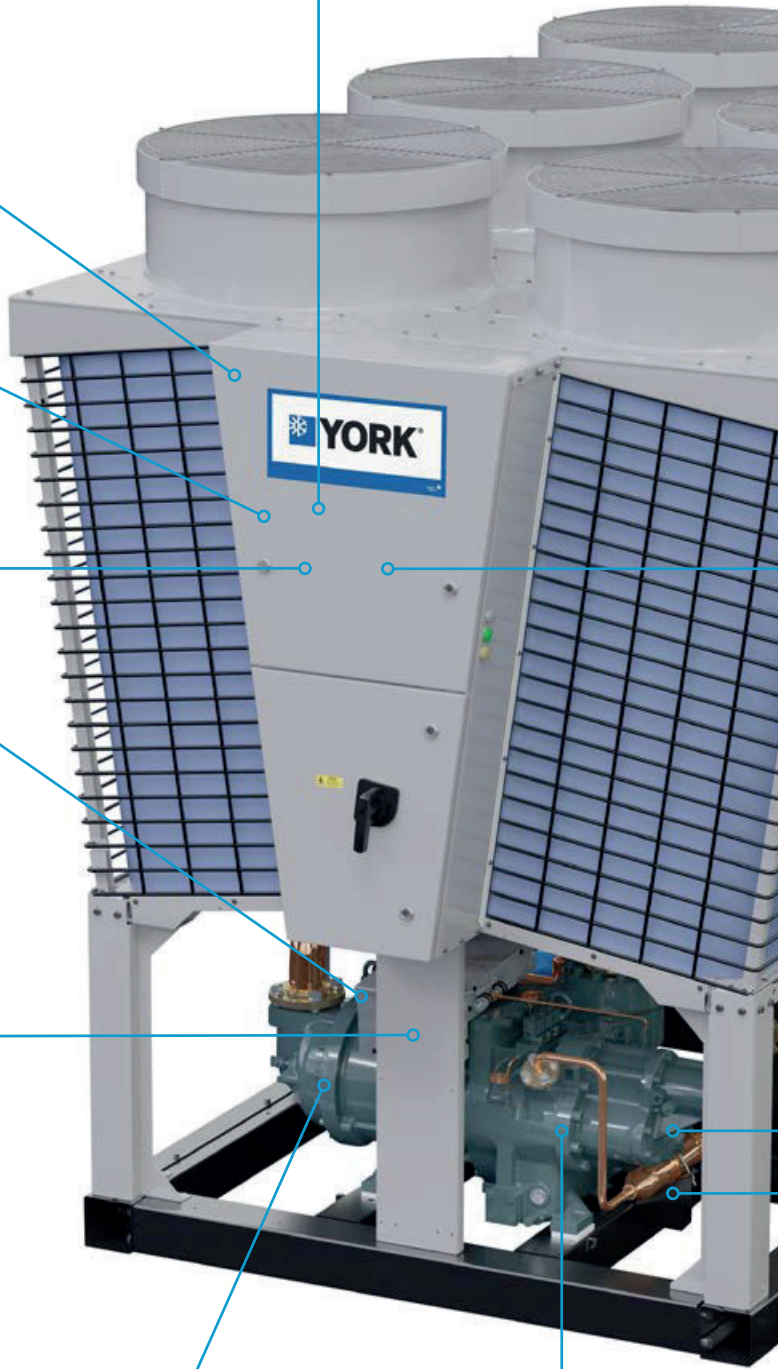

DC Motor and Fan

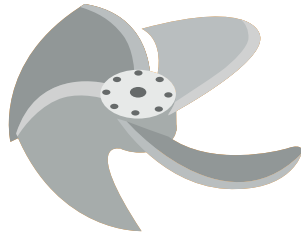

Power Cable Routing

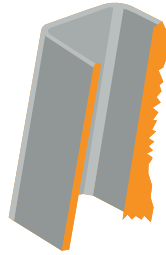

U-Shaped Heat Exchanger

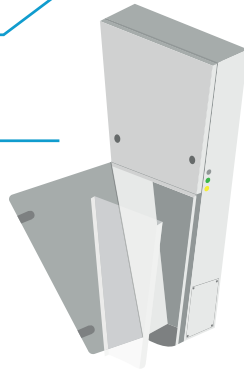

EBOX Louver Safety Cover



Increased Corrosion Protection



Unit Lower Panels and Sound Attenuation Options

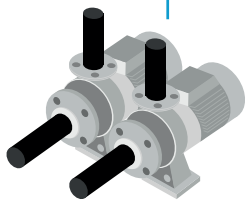

Pump Kit

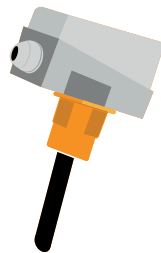

Water Flow Switch

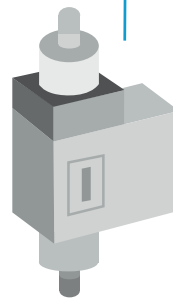

Water Differential Pressure Switch



Partial Heat Recovery



Optional Accessories



YCME / YHME

Air-cooled chiller and heat pump

Cooling capacities from 160 kW to 225 kW
 Heating capacities from 145 kW to 186 kW

YCME Air-cooled Chiller Performance Data

Individual modules		YCME0162HE	YCME0182HE	YCME0202HE	YCME0222HE
Cooling capacity	kW	160	180	205	225
Total power input	kW	51.3	57.7	65.4	70.9
SEER		4.11	4.13	4.12	4.12
$\eta_{s,c}$		161	162	162	162
Sound power level	dB(A)	96	97	98	99
Dimensions (H x W x D)	mm	2450 x 1955 x 2290		2450 x 1955 x 3230	
Operating weight	kg	1300	1340	1590	1680
Chilled Water Outlet (std, options Low / High)	°C	+5°C ~ +15°C, with Options -10°C ~ +5°C / +15°C ~ +30°C			
Ambient Air Temperature	°C	-15°C ~ +46°C			
Electrical Power Supply		3N - 400V 50Hz			

YHME Air-cooled Heat Pump Performance Data

Individual modules		YHME0162HE	YHME0182HE	YHME0202HE	YHME0222HE
Cooling capacity	kW	150	170	195	210
Total power input	kW	51.1	58.0	66.1	70.2
Heating capacity	kW	145	145	185	186
Total power input	kW	51.5	51.6	65.3	65.4
SCOP		3.22	3.22	3.25	3.25
$\eta_{s,h}$		126	126	127	127
Sound power level	dB(A)	96	97	98	99
Dimensions (H x W x D)	mm	2450 x 1955 x 2290		2450 x 1955 x 3230	
Operating weight	kg	1400	1420	1680	1760
Chilled Water Outlet (std, options Low / High)	°C	+5°C ~ +15°C, with Options -10°C ~ +5°C / +15°C ~ +30°C			
Heated Water Outlet	°C	+35°C ~ +55°C			
Ambient Air Temperature (Cool / Heat)	°C	-15°C ~ 46°C / -9.5 (DB), -10 (WB) ~ +21 (DB), +15.5 (WB)			
Electrical Power Supply		3N - 400V 50Hz			

Cooling operation: Chilled Water Inlet / Outlet Temperature: 12 / 7 °C / Condenser Inlet Air Temperature: 35 °C.
 Heating operation: Heated Water Inlet / Outlet Temperature: 40 / 45 °C / Evaporator Air Inlet Temperature: 6°C WB.
 Sound Pressure: measured at 1.5m height, and at 1m distance from the control panel.



YCSE / YCRE Style C

Water-cooled or remote air-cooled chiller

Cooling capacities from 140 kW to 250 kW

Nominal capacity and technical data

Model	Size	YCSE				YCRE		
		0141	0181	0221	0241	0141	0181	0221
Cooling Capacity *	kW	140	180	220	250	135	175	215
Total power input *	kW	28.0	36.3	45.4	51.3	32.0	41.8	52.4
EER		4.83	4.80	4.71	4.72	4.22	4.19	4.10
ESEER		5.35	5.69	5.71	5.72	Not Applicable		
SEER		5.14	5.46	5.51	5.52			
$\eta_{s,c}$		198	210	212	213			
Sound power level	kW	88	89	90	91	88	89	90
Length / Width / Height	mm	Base 1 378 max / 806 / 1 681						
Operating weight	kg	860	950	1 040	1 075	765	835	900
Chilled Water Outlet (std, options)	°C	+5°C ~ +15°C, with Options -10°C ~ +25°C						
Condenser Water Outlet	°C	+22°C ~ +60°C				+30°C ~ +60°C		
Electrical Power Supply		3N - 400V 50Hz						

* YCSE: At 35°C leaving condenser liquid temperature and 7°C leaving chilled liquid temperature according to EUROVENT calculation EN14511:2011
 * YCRE: At 45°C condensing temperature and 7°C leaving chilled liquid temperature

Dimensions YCME / YHME

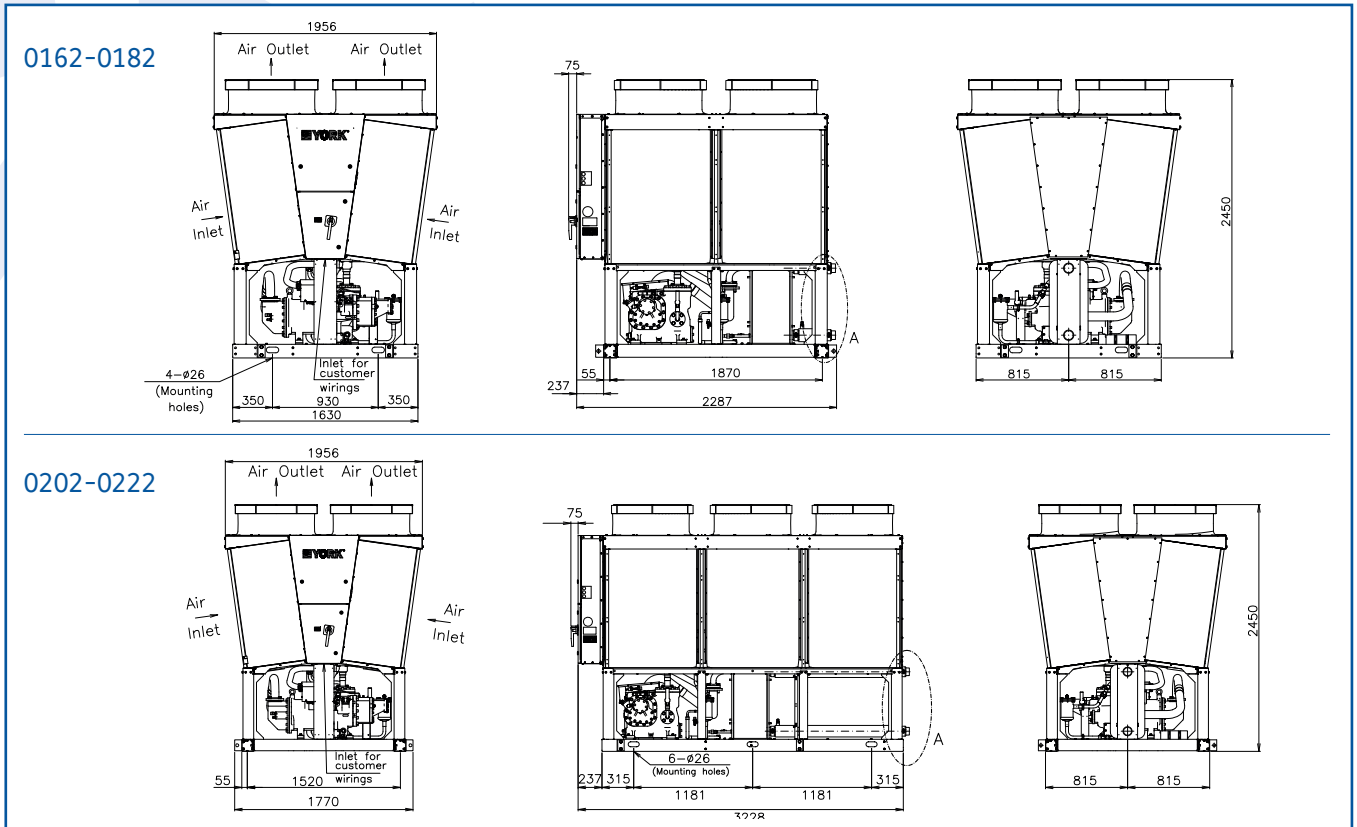

Dimensions YCSE

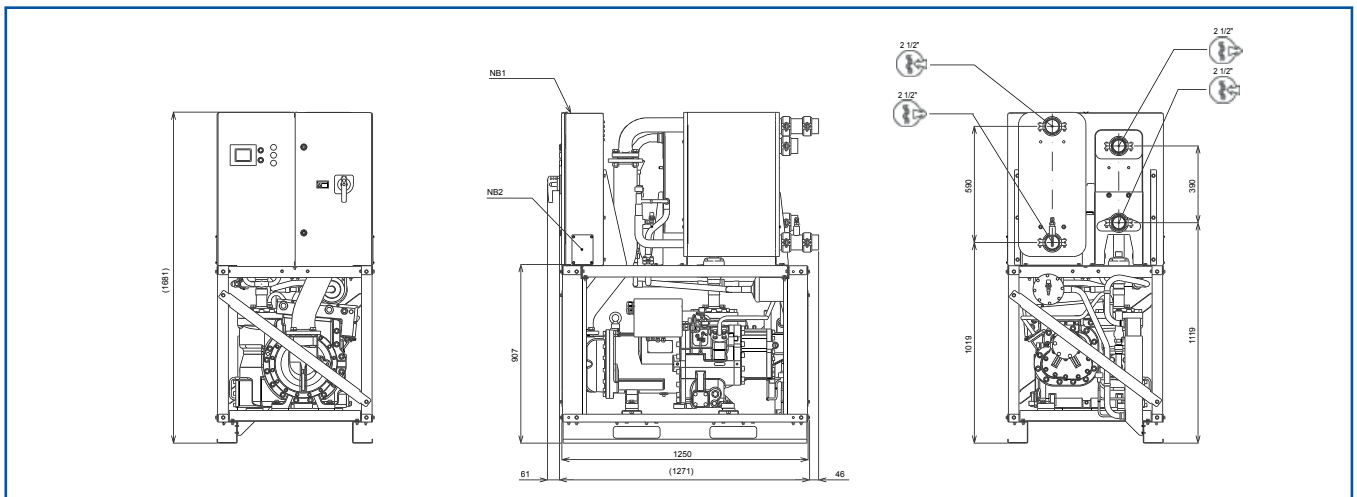

YORK[®]
 INSTALL CONFIDENCE.

PUBL-8312